

Libra 3405M/3412M

Libra 3405M/3412M are two global shutter mono camera developed by Tucsen for instrument integration. They utilize front-illuminated sCMOS technology, offering broad spectral response (350 nm~1100 nm) and high sensitivity in the near-infrared range. Equipped with global shutter and GigE interface, They provide faster speed for instruments, enhancing overall system performance.



Key Features

Benefits

High-Speed & Global Shutter ^[1]	Ideal for high speed slide scanning.
High Resolution	3.4 μm pixel size is good for 20x - 40x objective resolution.
Enhanced NIR Sensitivity	For multichannel fluorescent imaging.
Cooling for Low Light	Provides uniform imaging background and clean fluorescence images.
10G GigE & Compact Design	Conducive to the integration of instrument systems.

Typical Applications

- Slide Scanning
- Advanced Microscopy Imaging
- Industrial Inspection

Noted Examples

[1] The global shutter is conducive to capturing fast-moving objects, while the 10G GigE provides several times the speed compared to USB 3.0.

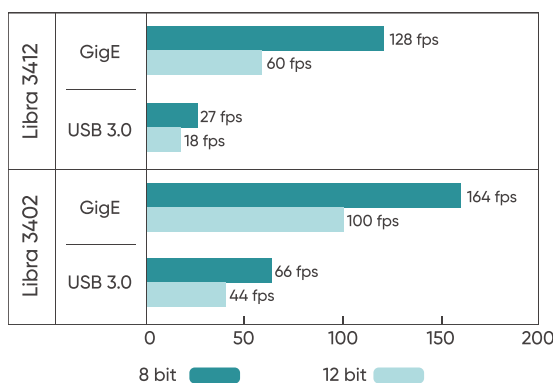

Quantum Efficiency

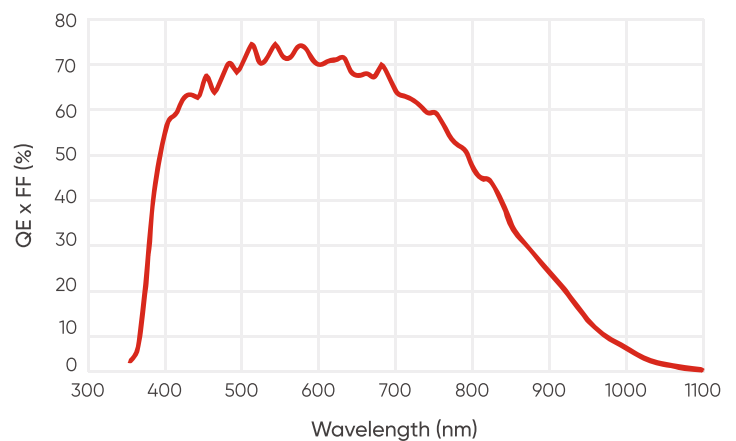

Dimensions (Unit: mm)

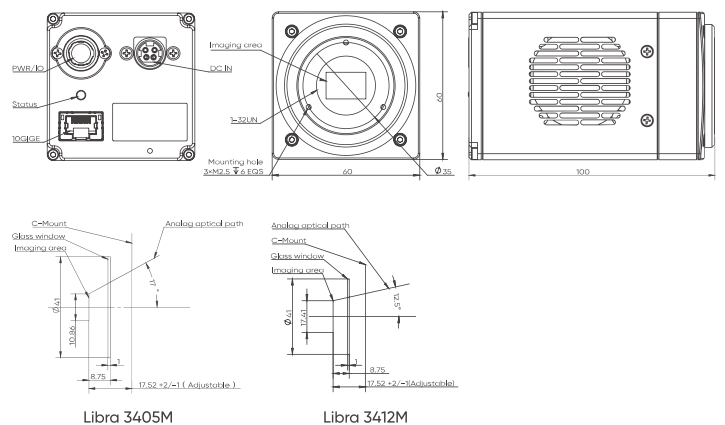

Model	Libra 3405M		Libra 3412M	
Sensor Type	FSI sCMOS			
Sensor Model	Gpixel GMAX 3405		Gpixel GMAX 3412	
Color / Mono	Mono			
Array Diagonal	10.9 mm (2/3")		17.4 mm (1.1")	
Effective Area	8.3 mm x 7.0 mm		14.0mm x 10.5mm	
Pixel Size	3.4 μm x 3.4 μm			
Effective Resolution	2448 (H) x 2048 (V)		4096 (H) x 3072 (V)	
Peak QE	75%@540 nm; 33%@850 nm			
Dark Current	3 e ⁻ /p/s@25°C			
Gain Mode	Standard (12 bit), Speed (8 bit)			
Full Well Wapacity	12 bit: 8.7 ke ⁻ @Gain 1, 0.5 ke ⁻ @Gain 2		12 bit: 9 ke ⁻ @Gain 1, 0.6 ke ⁻ @Gain 2	
Bit Depth	8 bit	12 bit	8 bit	12 bit
Frame Rate	164 fps	100 fps	128 fps	60 fps
Readout noise	12 bit: 3.9 e ⁻ @Gain 1, 1.6 e ⁻ @Gain 2		12 bit: 3.6 e ⁻ @Gain 1, 1.9 e ⁻ @Gain 2	
Shutter Mode	Global Shutter			
Exposure Time	12.2 μs ~ 10 s			
AI White Balance	Support			
Image correction	DPC			
ROI	Support			
Binning (FPGA)	1 x 1 , 2 x 2 , 4 x 4			
Cooling Method	TEC			
Cooling Temperature	Passive cooling: Chip is stable at 25°C@25°C(ambient); Air cooling: 10°C@25°C (ambient)			
Trigger Mode	Hardware, Software			
Output Trigger Signals	Exposure start, Exposure, Readout end, Contrast			
Trigger Interface	SMA			
SDK	C, C++, C#, Python			
Data Interface	10G GigE			
Optical Interface	C-Mount/Customizable			
Power	12 V/6A			
Power Consumption	T.B.D			
Dimensions	60 mm x 60 mm x 100 mm			
Camera Weight	T.B.D			
Camera Software	SamplePro, Mosiac V3, LabVIEW, MATLAB, Micro-Manager 2.0			
Operating System	Windows/Linux			
Operating Environment	Working: Temp. 0~40°C, HUM 10~85% Storage: Temp. -10~60°C, HUM 0~85%			