

Dhyana 400BSI V3

The Dhyana 400BSI V3 delivers perfect sensitivity and resolution for high NA microscope objectives, being designed lighter, and needing less power, making it ideal for integrating and fitting into small spaces.^[1]



Key Features

Benefits

95% QE & Lowest Noise	High signal-to-noise ratio across UV / Visible / NIR.
6.5 μm x 6.5 μm Pixel Size	Optimal spatial sampling and sensitivity for 100x, 60x and 40x microscope.
18 mm Array Diagonal	Ideal for the microscopes that have C-mount ports.
Rolling Shutter Control Mode	Allowed to define line time delays or slit heights for scanning systems such as Light-sheet Microscopy. ^[2]
Camera Link & USB 3.0	While the USB 3.0 is quite flexible and easy to use, the CameraLink is a faster and stable option up to 100 fps @ 4.2 MP.
Air & Liquid Cooling	Maintains low dark noise, minimizes vibration, and aids thermal stability.

Typical Applications

- Advanced Microscopy
- Spectral Imaging
- Astrophysical

Noted Examples

[1] Compact, lighter design requiring less power.

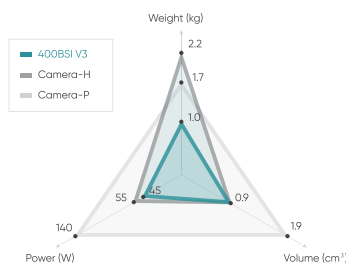

[2] The Rolling Shutter Control Mode applied in Light-sheet Microscopy.

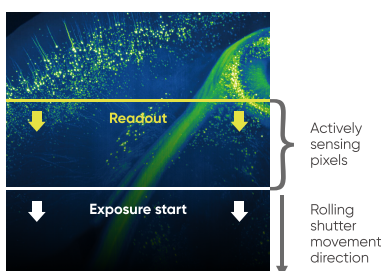

Quantum Efficiency

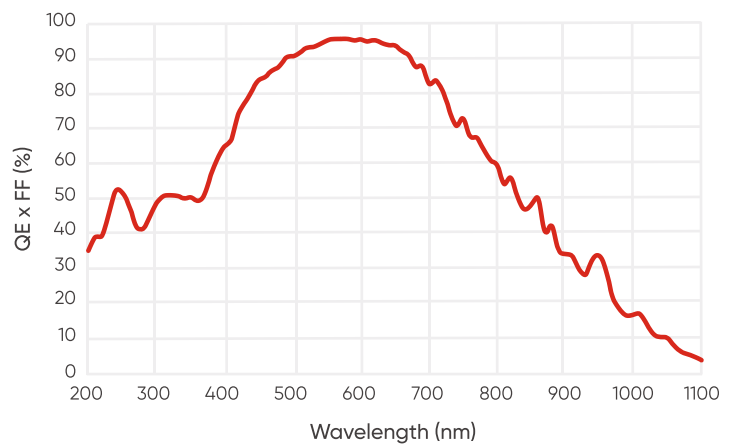

Dimensions (Unit: mm)

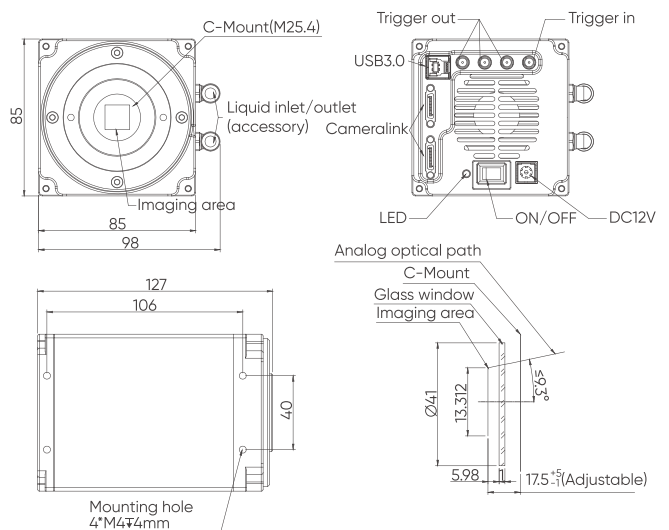

Specifications

High Sensitivity sCMOS Camera

www.tucsen.com

Model	Dhyana 400BSI V3	
Sensor Type	BSI sCMOS	
Sensor Model	Gpixel GSENSE2020BSI	
Peak QE	95% @ 600 nm	
Color/Mono	Mono	
Array Diagonal	18.8 mm	
Effective Area	13.3 mm x 13.3 mm	
Resolution	2048 (H) x 2048 (V)	
Pixel Size	6.5 μm x 6.5 μm	
Full-Well Capacity	Typ. : 45 ke-	
Dynamic Range	Typ. : 90 dB	
Frame Rate	12 bit Firmware HDR: 43 fps @ CameraLink, 43 fps @ USB 3.0 High Speed: 100 fps @ CameraLink, 60 fps @ USB 3.0	11 bit Firmware HDR: 74 fps @ CameraLink, 45 fps @ USB 3.0 High Speed: 100 fps @ CameraLink, 60 fps @ USB 3.0
Readout Noise	CMS(Typ.): 1.1 e- (Median) , 1.2 e- (Typ.): HDR(Typ.): 1.6 e- (Median) , 1.7 e- (RMS)	
Shutter Type	Rolling, Global reset	
Exposure Time	6.6 μs ~ 10 s	
DSNU	0.2 e-	
PRNU	0.3%	
Cooling Method	Air, Liquid	
Max. Cooling	45 °C below ambient (Liquid)	
Dark Current	0.5 e-/pixel/s @-10°C	
Binning	2 x 2, 4 x 4	
ROI	Support	
Timestamp Accuracy	1 μs	
Trigger Mode	Hardware, Software	
Output Trigger Signals	Exposure start, Global, Readout end, High level, Low level, Trigger Ready	
Trigger Interface	SMA	
Data Interface	USB 3.0, CameraLink	
Data Bit Depth	11 bit, 12 bit, 16 bit	
Optical Interface	C-mount	
Power Supply	12 V / 8 A	
Power Consumption	45 W	
Dimensions	85 mm x 85 mm x 127 mm	
Weight	995 g	
Software	Mosaic, SamplePro, LabVIEW, MATLAB, Micro-Manager 2.0	
SDK	C, C++, C#, Python	
Operating System	Windows, Linux	
Operating Environment	Working: Temp. 0~40 °C , HUM 10~85% Storage: Temp. 0~60 °C, HUM 0~90%	